

F-0279-030-0120

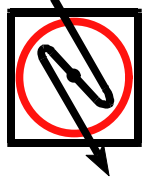

**Radionics<sup>®</sup>**

D279A Independent Zone Control (I.Z.C.)  

---

Operation and Installation Manual

# R A D I O N I C S

## D279A Independent Zone Control (I.Z.C.) Operation and Installation Manual

### Features

- Permits independent arming and disarming of a single control/communicator zone or point
- A 4-digit, user-programmable combination
- Built-in panic function
- Preprogrammed entry and exit delay times
- Individual annunciation of delayed and instant loop status
- Panic and burglary alarm signals to control/communicator
- Form C relay activation on alarm
- Keypad back-lights when number keys or the command bar are pressed
- Plug-in cable included for simple wiring to the control/communicator
- Low-profile surface mount enclosure

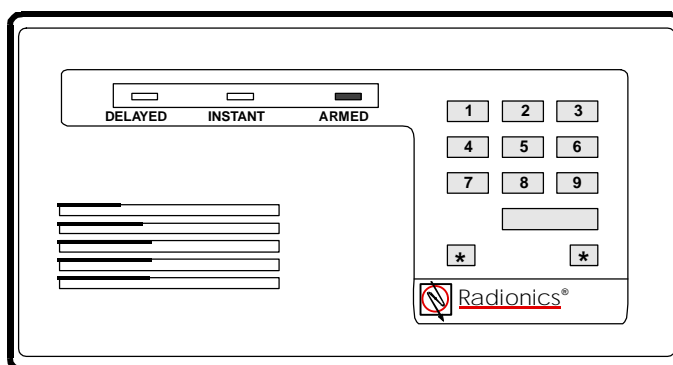

Figure 1: D279A Independent Zone Control

### Description

With a D279A, you can arm and disarm a single zone or point of a Radionics Control/Communicator panel separately from the rest of the system. The Independent Zone Control features a user-programmable 4-digit passcode for arming and disarming, and a built-in panic function. Entry and exit delay times allow you to locate the D279A Command Center inside the protected area. If you program the D7112, D8112, or D9112 for opening and closing reports, the D279A can initiate opening and closing reports by zone or point. A 10-wire cable is shipped with the D279A for interfacing the Independent Zone Control with the panel (4 wires), protective loops (3 wires) and onboard relay (3 wires).

**The D279A is not supervised from the panel:** UL Listed applications require arming device supervision. Use the D268/D269 Independent Zone Control to meet the UL requirement for arming device supervision.

### Operation

#### Loop Inputs

The D279A branches one zone or point of the panel into two separate loops: one delayed and one instant. Sensors can be wired to these loops in series (normally closed), or in parallel (normally open), or both. The loops are supervised by a 1K  $\Omega$  end of line resistor.

#### Delayed Loop

Faulting the delayed loop while the D279A is armed starts the entry delay time on both loops. Allowing the entry time to expire without disarming triggers an alarm, even if both loops are restored. Exit time is provided when arming.

## Instant Loop

Faulting the instant loop while the D279A is armed causes an immediate alarm. No entry time is provided unless the delay loop is faulted first. Exit time is provided when arming.

## Restorals

When both the delayed and instant loops return to normal after an alarm, the D279A is ready to detect another alarm. When one loop is faulted, a fault on the other loop cannot signal a new alarm to the panel. The restoral to the panel occurs three seconds after both loops are restored.

## Entry/Exit Delay

Both loops must be normal before the D279A can be armed. When you enter your passcode, an exit delay of 60 seconds is provided before the unit arms. When the I.Z.C. is armed, faulting the delayed loop starts an entry delay of 30 seconds. The D279A must be disarmed during this entry time to prevent an alarm. Once entry or exit delay starts, both loops are delayed.

## Arming and Disarming

Entering the passcode arms and disarms the D279A.

## Burglary Alarm Output

Opening or shorting the delayed or instant loop while the D279A is armed causes the output to short the panel zone (after entry delay on delayed loop) or point for a minimum of three seconds.

## Panic Alarm Function

Simultaneously pressing both asterisk buttons shorts the Panic output and initiates an alarm. Panic outputs from several D279A Independent Zone Controls can be connected to the same zone or point. If you do this, place the J4 jumper on the bottom two pins (see Figure 4). The Panic output can be connected to the same zone or point as the burglary alarm output, but if you do this, the Central Station will not be able to distinguish between panic and burglary alarms. It is recommended that you NOT wire panic and burglary alarm outputs together to zones or points programmed for opening and closing reports.

## Relay Output

A Form C relay (with normally open and normally closed contacts) is provided for connection to an optional annunciation device, such as a bell or light. (An external supply may be required to power this optional annunciation device.) The relay activates when the D279 goes into alarm. It resets when the D279A is disarmed.

**Panic (asterisk) buttons:** Pressing the Panic (asterisk) buttons does NOT activate the relay.

## Delayed LED

This green LED lights when the delayed loop is normal. It is not affected by armed status.

## Instant LED

This green LED lights when the instant loop is normal. It is not affected by armed status.

## Armed LED

This red LED is off while the Independent Zone Control is disarmed. It blinks after you enter your passcode to indicate exit time in progress, and remains lighted while the system is armed. It is not affected by alarms.

## Buzzer

During entry delay, the buzzer sounds steadily until an alarm occurs or the D279A is disarmed. If you press a numbered key while the D279A is disarmed and a loop is faulted, the buzzer indicates that the D279A is not ready to arm. The D279A can only be armed if both loops are normal.

## Lighted Keys

The D279A keys light during the entry delay period, and when you press number keys, or the command bar.

## Installation

You can mount the D279A directly onto a wall, installed in a flushmount unit, or attached to a D55 Desk Stand (see the special installation instruction sheet that comes with each item). Do not mount the D279A in a location exposed to direct sunlight. Direct sunlight makes the LEDs less visible, and intense heat can damage the D279A enclosure and electrical components.

**Wiring between the D279A and the panel is not supervised:** The wiring between the D279A and the panel is not supervised for trouble conditions. Wiring between the D279A and remote sensing devices is supervised with end-of-line resistors.

## Connecting the D279A to the Panel

1. Remove the front cover from the enclosure base (see Figure 2). Use a small flat-blade screwdriver to gently push the two bottom cover tabs back. As the tabs are pushed back, lift the bottom of the cover away from the base. Remove the cover.
2. Connect the D279A to the panel and protective zones or points as shown in Figure 3.
  - Install a 1K  $\Omega$  resistor beyond the last sensor of both the **Delayed** and **Instant** loops to provide a reference for supervision.
  - No terminating resistor is needed on the **Burglary** or **Panic outputs** to the panel.
  - If the **Panic** and **Burglary** outputs are connected to the same zone or point, place the J4 jumper on the bottom two pins (see Figure 4).
  - If the **Panic** outputs from several Independent Zone Controls are connected to the same zone or point, place the J4 jumper on the bottom two pins (see Figure 4) on all but one D279A.
  - **Burglary and panic outputs:** You cannot connect D279A Burglary and Panic outputs to the D6112 or D4112 powered loop inputs. Powered loop inputs are D6112 terminals 16, 17, 18, and 19; D4112 terminals 16 and 17; and D7112 terminals 23 and 24.
3. Route the 10-wire color-coded cable through the opening in the back of the enclosure base. Rotate the conductor so that the red wire (PIN 1) is pointing toward the bottom of the keypad and the orange wire (PIN 10) is pointing toward the top. Plug the connector into the back of the enclosure.
4. Place the enclosure base on the wall in the desired location, and mark the locations of the mounting holes. (The base can be mounted to a single-gang wall box. The two mounting screw holes in the base of the D279A are positioned for standard single-gang compatibility.) Secure the enclosure base to the wall or gang box.
5. Push each key on the keypad towards the top of the enclosure to ensure proper mating with the openings in the top cover.
6. Align the top two tabs of the enclosure cover with the top two tab slots in the enclosure base. Slide the top of the cover into the base. Gently push the bottom of the cover down on the base until it snaps into place.
7. Program the passcode (see *User Passcode*).

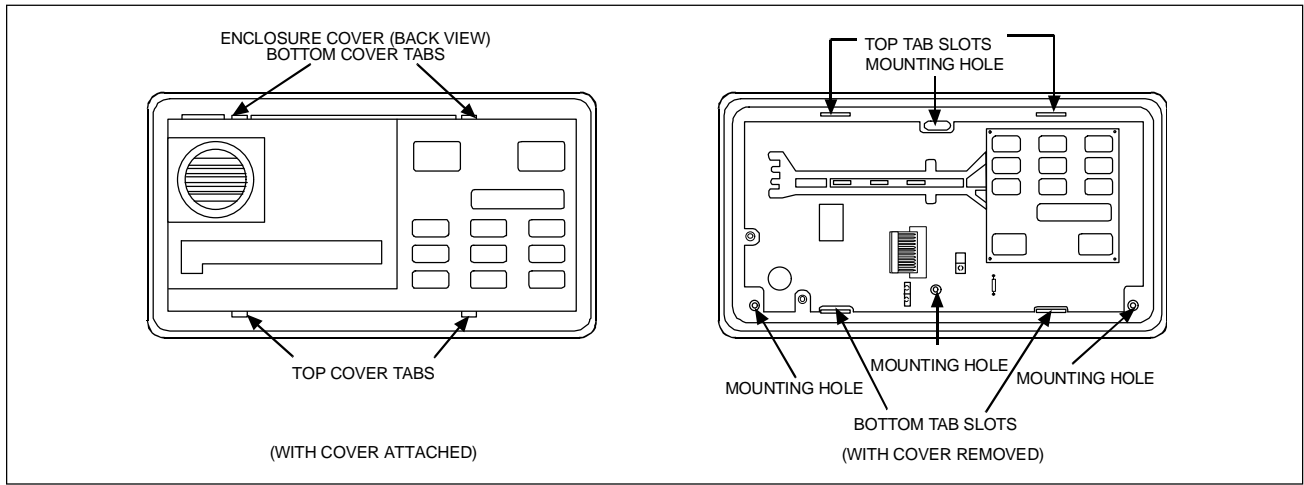

Figure 2: Installing the D279A

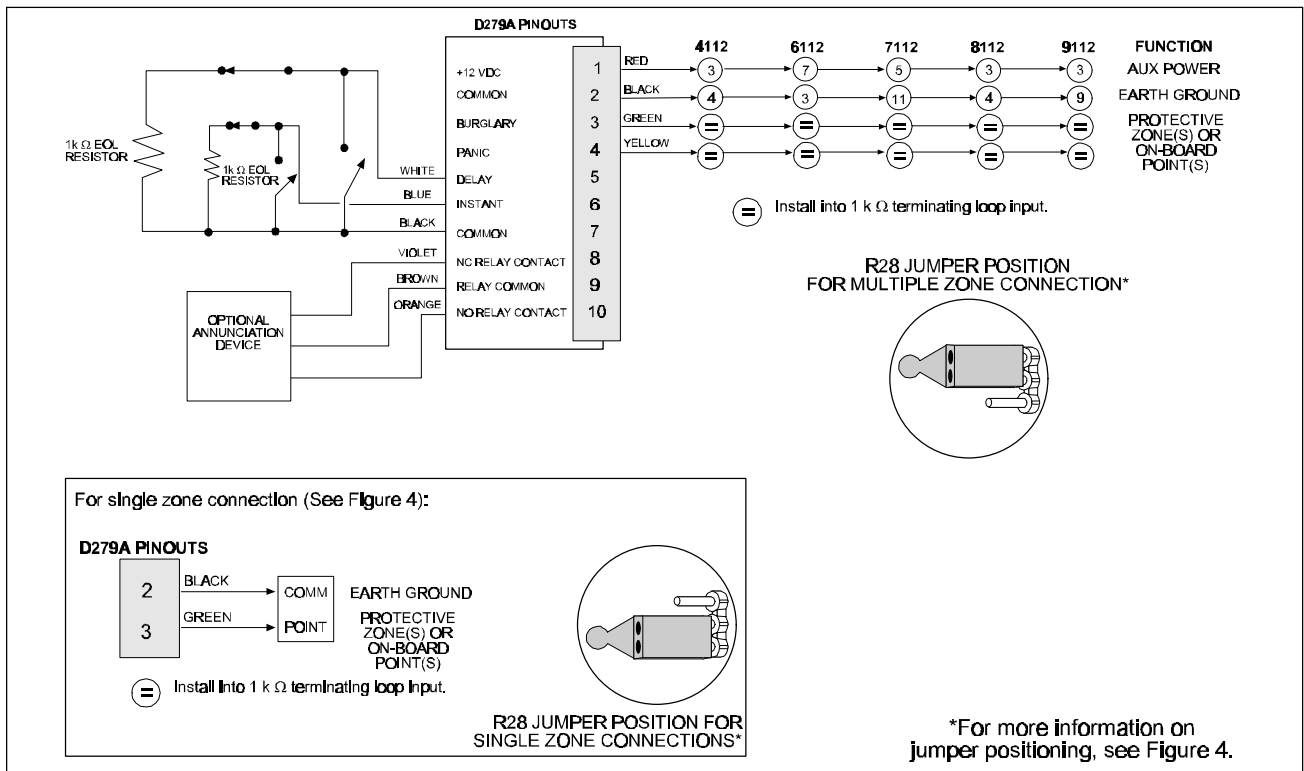

Figure 3: Wiring the D279A

### Connecting the D279A to the D55 Desk Stand

The wiring cable (with modular plug) that is included with the Desk Stand is not compatible with the D279A. To install a D279A onto a D55 Desk Stand:

1. Remove the cover as described previously
2. Plug the 10-wire cable into the D279A
3. Route the cable through the hole in the desk stand
4. Screw the base to the Desk Stand, and replace the cover

To disconnect the D279A, reverse this procedure. The D279A cable plug cannot be removed through the Desk Stand hole.

## User Passcode

The D279A Independent Zone Control comes programmed with a standard passcode of 1234. Once the unit is installed and power connected, you can change these numbers to the desired four digit passcode.

### Recovering the Standard Passcode

Default passcode procedure:

1. Make sure the D279A is in disarm state.
2. Connect jumper J3 across the top two pins.
3. Press the BLANK key once.
4. Enter the mastercode 0279 twice. (Blank key is also 0 key)
5. The buzzer sounds a beep for 3 sec. to indicate default passcode success.
6. Arm and disarm the zone control to test the default passcode 1234.

### Programming or Changing the Passcode

A four digit passcode is used to arm and disarm the D279A. This code can be changed only by first knowing the existing (old) passcode. Change the passcode only while the D279A is DISARMED, and BOTH protective loops are normal. If you make a mistake while programming, restart the procedure from step 2. If programming is not completed in 60 seconds, the Independent Zone Control reverts to the old passcode. As shipped, the J3 jumper plug is placed across the top two pins, which enables passcode change (see Figure 4). The passcode change feature is disabled when the jumper plug is placed across the bottom two pins.

1. Connect jumper J3 across the top two pins.
2. Press the BLANK key once.
3. Enter the old passcode once (1234 or 2222 when first installed).
4. Enter the new four digit passcode twice.

DO NOT program the same digit twice in a row (example: 4556).

DO NOT program the first and last digit the same (example: 4564).

DO NOT use the BLANK (zero) key for any digits in the passcode (example: 1023).

5. Arm and disarm the zone control to test the new passcode.



To prevent further use of this feature, place jumper J3 across the bottom two pins (see Figure 4).

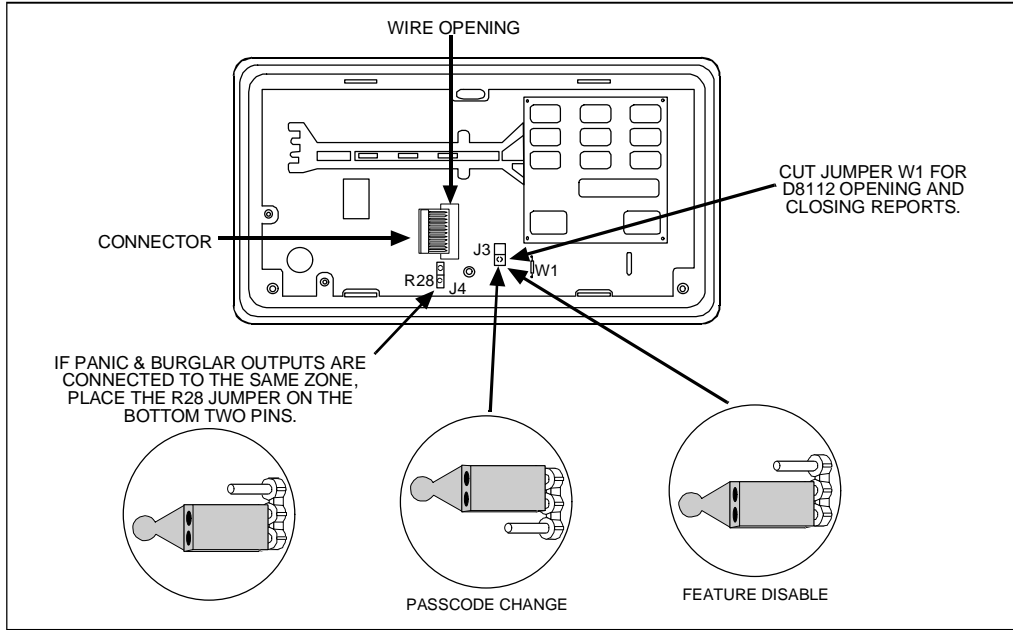

Figure 4: D279A Printed Circuit Assembly

## Programming the D8112 Panel Protective Zone

The D279A controls arming/disarming and entry/exit delay for the zone input to which it is connected. Independently controlled zones use distinctive zone codes that do not follow typical zone code programming rules. The first two digits of the zone code follow Special Zone Code programming. The last two digits follow standard programming parameters as detailed in the Zone Code Index of the *8112:MAIN Program Entry Guide*. (See the *8112:MAIN Program Entry Guide* for complete Independent Zone Control zone code programming details.) Figure 4 shows some recommended zone codes for use with the D279A.

### Supervised Independent Zone Controls (Opening and Closing Reports)

To supervise the I.Z.C., program zone codes with 3 in the first digit position and 2 in the second digit position. The 3 2 - - code is a Special Zone Code used by the D8112 to identify a supervised I.Z.C. zone. To enable opening and closing reports from the zone controlled by the D279A, cut the jumper (a violet colored jumper, see Figure 4) located on the D279A. The D279A burglary output will go from open to normal (1K) when the control is armed (closed).

**Opening and closing reports by zone:** When using the D279A to send opening and closing reports by zone, do not use the same number for the D279A zone number as you do for the passcode ID or the reporting number (see *8112:MAIN Program Entry Guide*, section 8. *Arm/Disarm Supervision Reports* for passcode ID reporting numbers). **Example:** If the D279A is connected to zone 8, DO NOT USE passcode 8 or COMEX group 8.

### Non-Supervised Independent Zone Controls (No Opening and Closing Reports)

For a non-supervised I.Z.C. zone program the zone code with 3 in the first digit position and 4 in the second digit position. The 3 4 - - code is a Special Zone Code used by the D8112 to identify a non-supervised I.Z.C zone. When the zone code begins with 3 4, opening and closing reports are not transmitted from the zone controlled by the D279A.

## Priority Zone Functions

Programming the D279A as a priority zone enables two valuable functions. When the zone code for the D279A is programmed with a 3, 4, 7, or 8 in the fourth digit position, the I.Z.C. zone must be armed before the system can be master armed. However, once the D8112 is armed, the D279A may be armed and disarmed. In addition, priority zone programming provides for an arm/disarm status display at the command center for the I.Z.C. zone. Pressing any key displays the disarmed priority zone as a faulted zone. Cut jumper W1 to enable the priority zone feature (W1 is a violet colored jumper, see Figure 4).

Some standard priority sub-control zone codes are shown below:

- 3233 Supervised, no restoral reports, steady bell on alarm, Alpha II display visible, priority zone.
- 3433 Non-supervised, no restoral reports, steady bell on alarm, Alpha II display visible, priority zone.
- 3274 Supervised, restoral reports, steady bell on alarm, Alpha II display visible, priority zone with swinger shunt.

FORMAT	Cut W1* on D279A	Digit 1	Digit 2	Digit 3	Digit 4
<b>No Opening/Closing</b>					
Audible		3	4	3 or 7	1 - 8
Silent		3	4	1 or 5	1 - 8
Priority Zone	YES	3	4	1,3,5,6 or 7	3 or 4
Bell Control From D279	YES	3	4	3 or 7	1 - 8
<b>Opening/Closing</b>					
Audible	YES	3	2	3 or 7	1 - 8
Silent	YES	3	2	1 or 5	1 - 8
Priority Zone	YES	3	2	1,3,5,or 7	3 or 4
Bell Control From D279	YES	3	2	3 or 7	1 - 8

**Figure 5: Recommended D8112 Zones Codes**

**\* Bell Control from the D279A:** When jumper W1 OPENING/CLOSING on the D279A is cut, entering the D279A passcode silences the bell output of the D8112. The D279A silences only those alarms initiated by its zone input to the D8112; it cannot silence alarms initiated by the D279A Panic Alarm Output, unless fire and burglary inputs are connected to the same zone.

The bell time restarts with every new trip on the zone input. The D279A cannot deactivate the Silent Alarm Output (D8112 terminal 8) if the zone is programmed "Silent."

## Audible Alarms

The D8112 can be programmed to sound an audible alarm when the D279A is tripped while armed. The D8112 must be programmed with a bell time and the D8112 zone code must be programmed for audible alarms.



## Programming the D7112 Panel Point

The D279A controls arming/disarming and entry/exit delay for the point to which it is connected.

### Supervised Independent Zone Controls (Opening and Closing Reports)

To supervise the I.Z.C., program the point code as 70000. To enable opening and closing reports from the zone controlled by the D279A, cut the jumper labeled W1 OPEN/CLOSE (a violet colored jumper, see Figure 4) located on the D279A. The D279 sounds audible alarms when the 70000 point code is used.

## Programming the D6112 and D4112 Panel Protective Zone

The D279A controls arming/disarming and entry/exit delay for the zone input to which it is connected. The D279A cannot be used to generate opening and closing reports, or silence the bell (through the software) with a D4112 or D6112. See the *D4112 Installation and Programming Manual* or *6112:MAIN Program Entry Guide* for complete zone code programming details.

**W1 jumper:** For normal operation with the D4112 or D6112, do NOT cut jumper W1. However, if you want to display the D279A armed or disarmed status at the D4112 or D6112 command center, or if you want to put the D279A on a priority zone, cut jumper W1.

Some standard sub-control zone codes are shown below:

01150	24 hour zone, trouble on open, instant alarm on short, steady bell on alarm, restoral reports
04110	24 hour zone, instant alarm on short, no trouble conditions, steady bell on alarm
04100	24 hour zone, instant alarm on short, no trouble conditions, steady bell on alarm, local zone
04150	24 hour zone, instant alarm on short, no trouble conditions, steady bell on alarm, restoral reports

**Using the 01- - - zone code:** The 01- - - code only supervises the protective zone wire between the D279A and the D4112/D6112. It is recommended that you DO NOT cut jumper W1 when using this code. If you cut the jumper, the D279A sends a trouble report when disarming, and a restoral report when arming.

### Audible Alarms

The D4112 and D6112 can be programmed to sound an audible alarm when the D279A is tripped while armed. The D4112 or D6112 must be programmed with a bell time and the zone code must be programmed for audible alarms.

## Programming the D9112 for the D279A

The D279A can be used in one of two ways with the D9112: The D279A controls arming/disarming and entry/exit delay for the point input it's connected to. If the W1 jumper is cut, point opening and closing reports may also be sent. In this configuration, however, bell control from the D279A is not available. If the D279A is tripped into an alarm condition and is programmed to sound the bell, you must silence the alarm bell using the command center it's assigned to. You can also use the D279A's on-board Form C relay to provide a bell output and thus allow bell control from the D279A. You may use Point Index #31 from the default Program Record Sheet for the D279A for this application.

The D279A can also be used to arm and disarm individual areas. When using it in this configuration, the D279A should be the only point in the area. The scope of the command center should be programmed to include the D279A's area (either Account Wide or Panel Wide scope). Cut the W1 jumper on the D279A to send area opening and closing reports *and* to provide bell control from the D279A. Assign a passcode to the D279A's area with an authority level for which no functions are enabled; this allows you to silence the bell only in the area in which the passcode is assigned. You may use Point Index #28 from the default Program Record Sheet, with one modification: Program the point response 2 instead of 1.

## Programming the D9000/7000 "C" Version Panels

The D279A can also be used in two ways on any D9412, D9112, D7412 or D7212 C version panels. To use the D279A as an individual protected area, connect the D279A to a *single* point on the D9000/7000 control panel. Use the burglary (green) output to activate the point on the D9000/7000 control panel. The D279A is Open when disarmed and Normal when armed. (No EOL resistor is needed.) The D279A can also arm and disarm an entire area. In this application, the point connected to the burglary (green) output should be the only point assigned to the area. The status of the area can be viewed from any keypad with panel wide scope. See the Program Entry Guide for the D9000/7000 control panel for more information.

If programming the D279A with D9000/7000 C panels, you can use point index 17 (O/C non-priority) or point index 18 (O/C priority) to program points for use with the D279A. Cut the W1 jumper on the D279A to send Point Opening and Point Closing reports. If the D279A's jumper is not cut, then no open or close reports are sent regardless of the panel programming.

### Assigning the D279A to a Point with Index 17

**The Point Response must be programmed as 1 (one).** Points assigned to Point Index 17 will respond as follows:

NORMAL	The point is Armed and sends a Point Closing report
OPEN	The point is Disarmed and sends a Point Opening report
SHORT	The point is in Alarm when the D279 is armed and is in Trouble when the D279A is Disarmed. This will allow supervision of the wiring between the D279A and the panel.

A D279A programmed for non-priority does not affect the assigned area when armed. See the D9000/7000 Program Entry Guide for more information.

### **Assigning the D279A to a Point with Index 18**

**The Point Response must be programmed as 2 (two).** Points assigned to Point Index 18 will respond as follows:

NORMAL	The point is Armed and sends a Point Closing report if W1 is cut.
OPEN	The point is Disarmed and sends a Point Opening report if W1 is cut.
SHORT	The point is in Alarm when the D279A is armed and is in Trouble when the D279A is Disarmed. This will allow supervision of the wiring between the D279A and the panel. When the point changes from Short to Normal or Open, a restoral is sent.

A D279A programmed for priority must be armed before the rest of the area including the D279A can be armed. See the D9000/7000 Program Entry Guide for more information.

## **Specifications**

### **Operating Voltage**

Nominal 12VDC

### **Current Requirements**

Keypad Idle: 60 mA

Keypad lighted, buzzer on, both loops faulted, and relay activated: 104 mA

### **Auxiliary Relay Rating**

Form C contacts, 12VDC, 2 Amps max.

### **D279 Dimensions**

Height 4.56" - Length 8.15" - Depth 0.816"

### **Wiring**

A 10-wire quick-connect plug-in cable is provided for interfacing the D279 with the Control/Communicator and the protective loops. 22 AWG (1.2 mm) or heavier gauge wire required to connect the loops and control/communicator to the ten flying leads.

5  $\Omega$  maximum resistance on common. 20  $\Omega$  maximum resistance on all other runs between the D279 and the panel.

### **Operating Temperature**

0°C to 50°C (32°F to 122°F)

### **Non-condensing Relative Humidity**

5% to 85% at 30°C (86°F)

## FCC Notice

This equipment generates and uses radio frequency energy. If not installed in accordance with the manufacturer's instructions, it may cause interference to radio and television reception. It has been type tested and found to comply with the specifications in Sub-part J of Part 15 of FCC rules for Class B Computing Devices. If this equipment causes interference to radio or television reception - which can be determined by turning the equipment on and off - the installer is encouraged to correct the interference by one or more of the following measures: 1) Reorient the antenna of the radio/television, 2) Connect the AC transformer to a different outlet so the control panel and radio/television are on different branch circuits, 3) Relocate the control panel with respect to the radio/television.

If necessary, the installer should consult an experienced radio/television technician for additional suggestions, or send for the "Interference Handbook" prepared by the Federal Communications Commission. This booklet is available from the U.S. Government Printing Office, Washington D.C. 20402, stock no. 004-000-00450-7.

® The Radionics logo is a registered trademark of Radionics, a division of Detection Systems, Inc.  
© 1999 Radionics, Salinas, CA, U.S.A. All rights reserved.



**Radionics**®

Radionics, P.O. Box 80012  
Salinas, CA, 93912-0012, U.S.A.  
Technical Support: (800) 538-5807